

<b>Estimate Request Sheet and Specification Drawing</b>  <b>TO : SHOWA INSTRUMENT INFORMATION CO., LTD.</b> <b>Fax 03-3431-9413</b>	<b>Estimate Client</b>		Date
	Company Name		Section
	Issuer by	FAX	TEL

Estimate it by this specification

800以上

TAG NO.		
Fluid Name		
Scale	Max.	
	Min.	
	Normal	
density SP.GR.		
Viscosity		
Temperature	°C	
Pressure	MPa	
Fin	Yes, No	Yes, No
Dumper	Yes, No	Yes, No
Accuracy	±2% F.S	
Painting	Body: Munsell N-6.5	
	Case: Silver	
Connection Standard	JIS 10K-RF	
Nominal Pipe Size		
Quantity		

Fin or damper structure of option

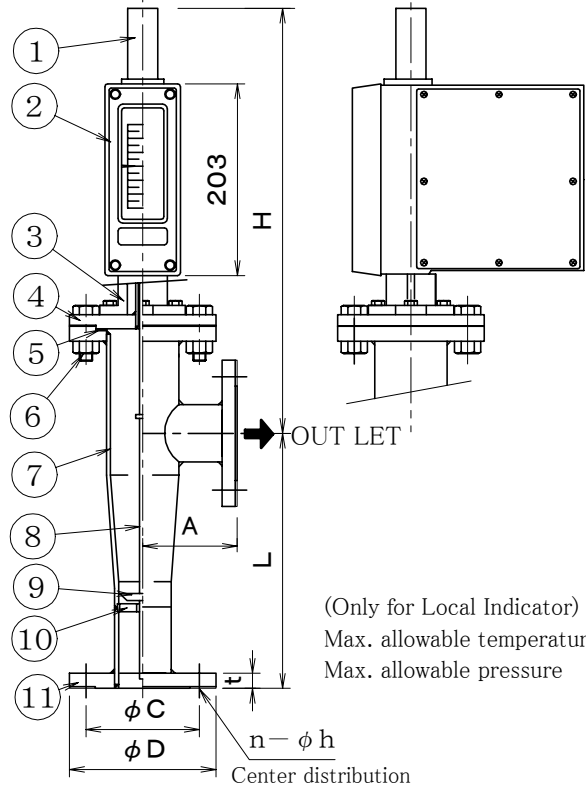
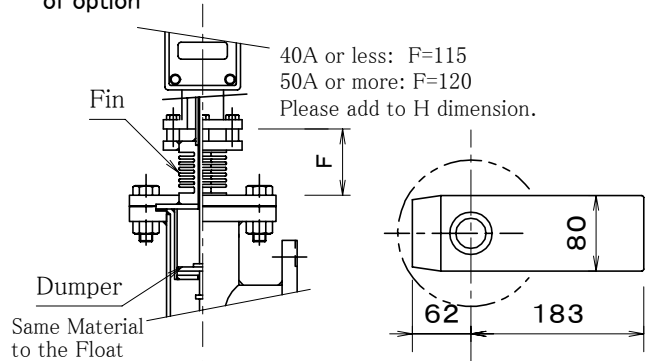

A part of case externals differs by the kind of the option. Please refer to an attached drawing of the table below.

Option of order (☒ Point)		
Type	Option	
<input type="checkbox"/> Non	Non	
<input type="checkbox"/> E2	4-20mA Transmitter	
<input type="checkbox"/> E2X	d2G4/4-20mA	
<input type="checkbox"/> S2	Totalizer	
<input type="checkbox"/> A21	1 Contact for Alarm	
<input type="checkbox"/> A22	2 contact for Alarm	
<input type="checkbox"/> A21X	d2G4/1 Contact for Alarm	

11	Flange	SS400	3
10	Stopper	SUS304	1
9	Float	SUS304	1
8	Rod	SUS304	1
7	Body/Taper Tube	SUS304	1
6	Bolt/Nut	SUS304	1set
5	Gasket	V/#1500	1
4	Upper Flange	SS400	1
3	Stand	ADC12	1
2	Case	ADC12	1
1	Cap	ADC12	1
No.	Part Name	Materials	Q'ty

Refer to a JIS standard for flange dimension mm

口径	A	L	H	口径	A	L	H
15,20A	80	220	420	65A	120	300	470
25,32A	100	250	420	80A	150	320	480
40A	100	250	440	100A	180	350	500
50A	100	270	450				

Name	Metal Taperd tube VARIABLE AREA FLOWMETER	Estimate	Made by	Aprobed by
Model No.	ML-5020	Estimate No.		

SHOWA INSTRUMENT INFORMATION CO., LTD.  
Sales Department