

Estimate Request Sheet and Specification Drawing TO : SHOWA INSTRUMENT INFORMATION CO., LTD. Fax 03-3431-9413	Estimate Client		Date
	Company Name		
	Issuer by		Section
FAX		TEL	

Estimate it by this specification

TAG NO.		
Fluid Name		
Scale	Max.	
	Min.	
	Normal	
density		
Viscosity		
Temperature		°C
Pressure		MPa
Accuracy		±2% F.S
Run a Way		Up ward
Painted Color		N-6.5 Gray
Connection Standard		JIS10K-RF
Nominal Pipe Size		
Accessory		
Quantity		

Max. Operating pressure
 1.0MPa / less than 40A of pipe size
 0.8MPa / more than 50A of pipe size
 Max. Operating temperature 120°C

Nominal Size	L	D	C	f	t	n-h
10A		90	65	1	14	4-15
15A		95	70	1	16	4-15
20A		100	75	1	18	4-15
25A		125	90	1	18	4-19
32A	220	135	100	2	20	4-19
40A		140	105	2	20	4-19
50A		155	120	2	20	4-19
65A		175	140	2	22	4-19
80A		185	150	2	22	8-19
100A	250	210	175	2	24	8-19

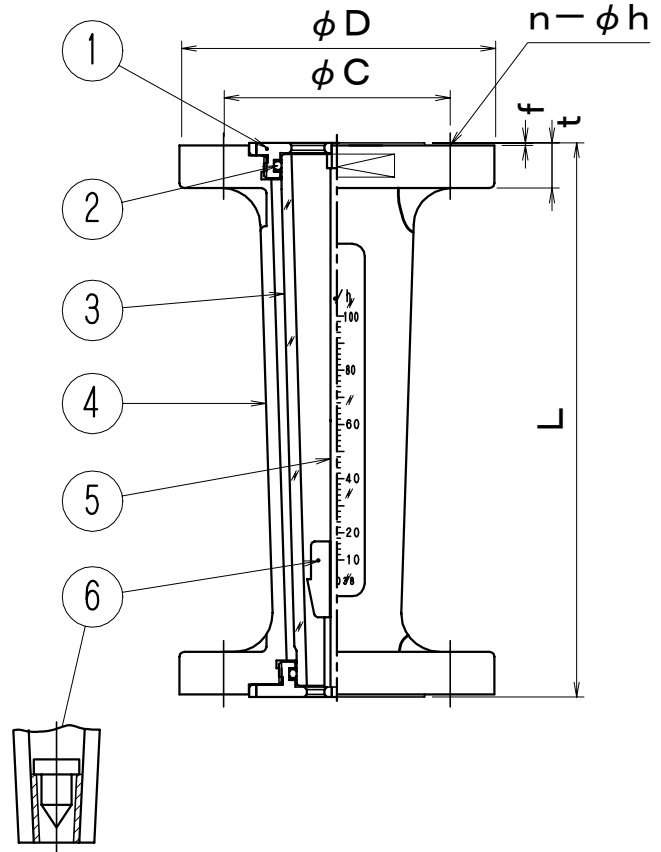

When without Guid rod

No.	Part Name	Materials	Q'ty	Remark
6	Float	SUS304	1	
5	Rod	SUS304	1	
4	Housing	FCD40	1	Painting
3	Taperd Tube	polysulfone resin	1	
2	O-Ring	NBR	2	
1	Fitting	SUS304	2	

Name	transparent Taperd tube VARIABLE AREA FLOWMETER	Estimate	Made by	Aprobed by
Model No.	flanged AP-0200		Estimate No.	

SHOWA INSTRUMENT INFORMATION CO., LTD.
Sales Department