

Estimate Request Sheet and Specification Drawing		Estimate Client		Date
TO : SHOWA INSTRUMENT INFORMATION CO., LTD. Fax 03-3431-9413		Company Name		
		Issuer by	Section	
		FAX	TEL	

Estimate it by this specification

TAG NO.			
Fluid Name			
Scale	Max.		
	Min.		
	Normal		
density			
Viscosity			
Temperature		°C	
Pressure		MPa	
Direction of flow		→	
Accuracy		±3% F. S	
Painted Color		Body: no paint Case: Black	
Connection Standard		Rc1/2	
Nominal Pipe Size		15A	
Accessory			
Quantity			

Max. Operating pressure: 1.4MPa  
Max. Operating temperature: 120°C

11	Case Cover	Reinforced P.P	1	
10	Case	ADC12	1	
9	Bolt/Nut	SUS304	8	
8	Cover Flange	SUS304	1	
7	Flapper	SUS316	1	
6	Spring	SUS316	1	
5	Shaft	SUS316	1	
4	bearing plate	SUS304	1	
3	O-Ring	NBR	1	
2	Body	SUS304	1	
1	Vent Plug	SUS304	1	
No.	Part Name	Materials	Q'ty	Remark

Flow direction and flowmeter position

left→right   left←right   bottom→top   top→bottom

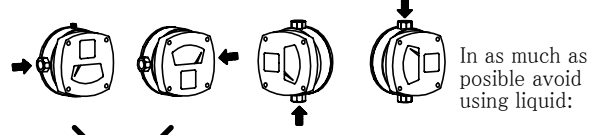

do not install the model with the scale facing upwards.

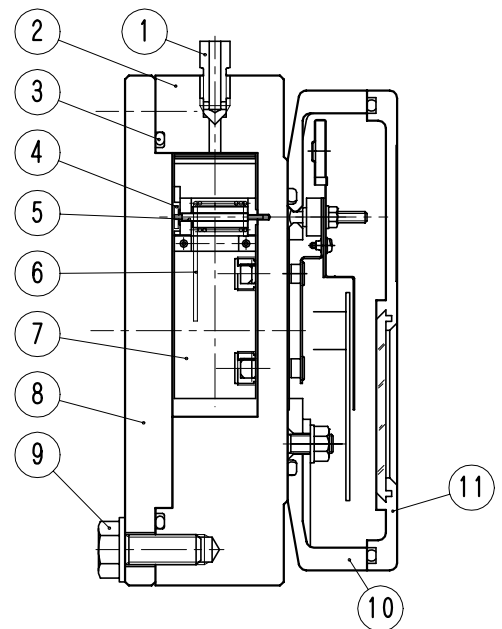
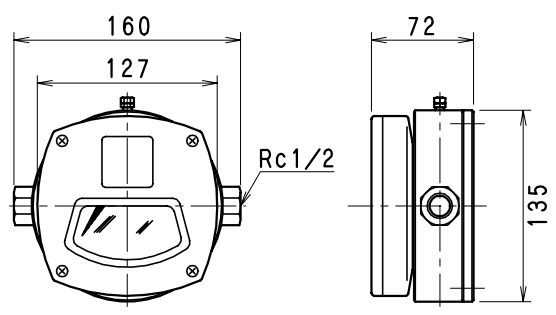

Name	Flapper type Variable Area Flowmeter Small "FLAPTOR"®	Estimate	Made by	Aproved by
Model No.	Indicating only FM-0355		Estimate No.	
<b>SHOWA INSTRUMENT INFORMATION CO., LTD.</b> Sales Department				